

Lüftungsanlage Büro L01

Auslegungsbedingungen:
 Winter:
 Außentemperatur -13°C
 Zulufttemperatur +22°C
 Ablufttemperatur +20°C
 Sommer:
 Außentemperatur +32°C
 Zulufttemperatur +20°C
 Ablufttemperatur +26°C

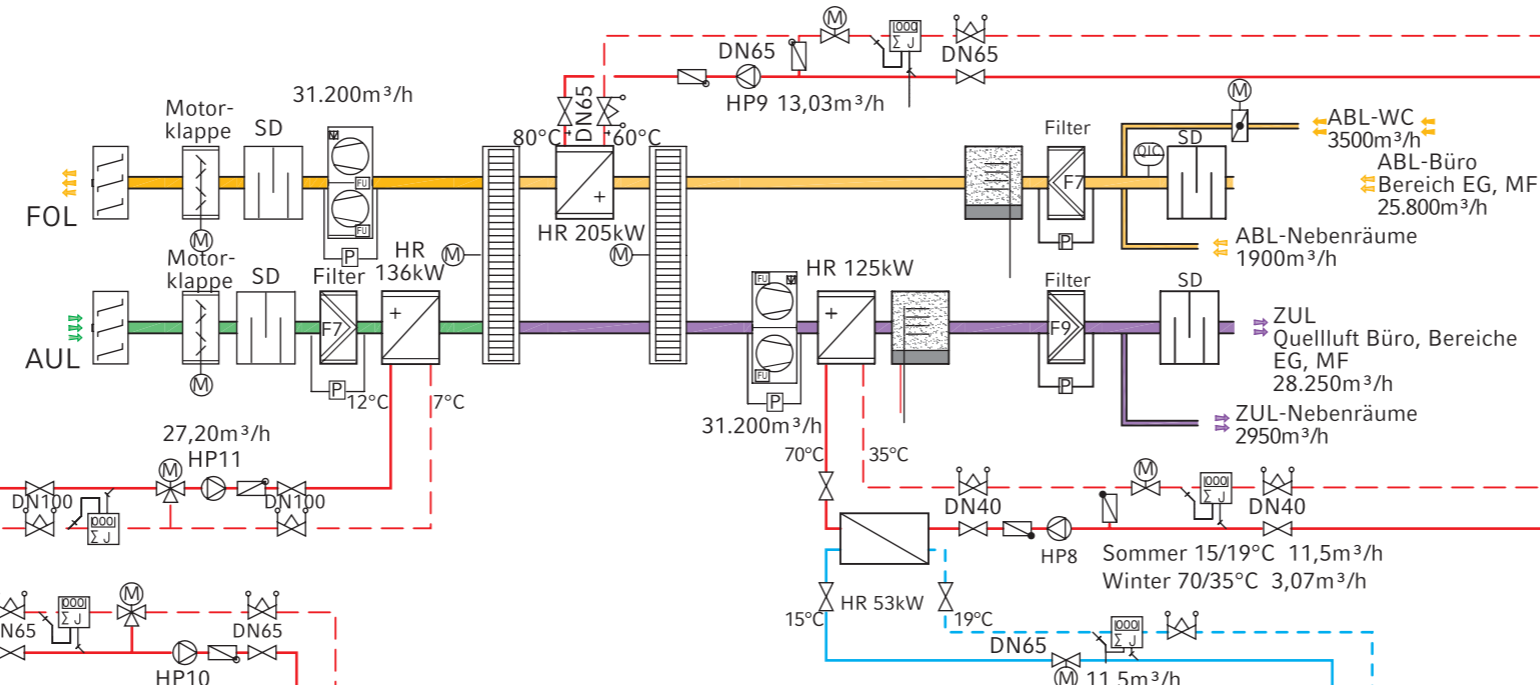

Lüftungsanlage Küche L02

Auslegungsbedingungen:
 Winter:
 Außentemperatur -13°C
 Zulufttemperatur +22°C
 Ablufttemperatur +20°C
 Sommer:
 Außentemperatur +32°C
 Zulufttemperatur +22°C
 Ablufttemperatur +26°C

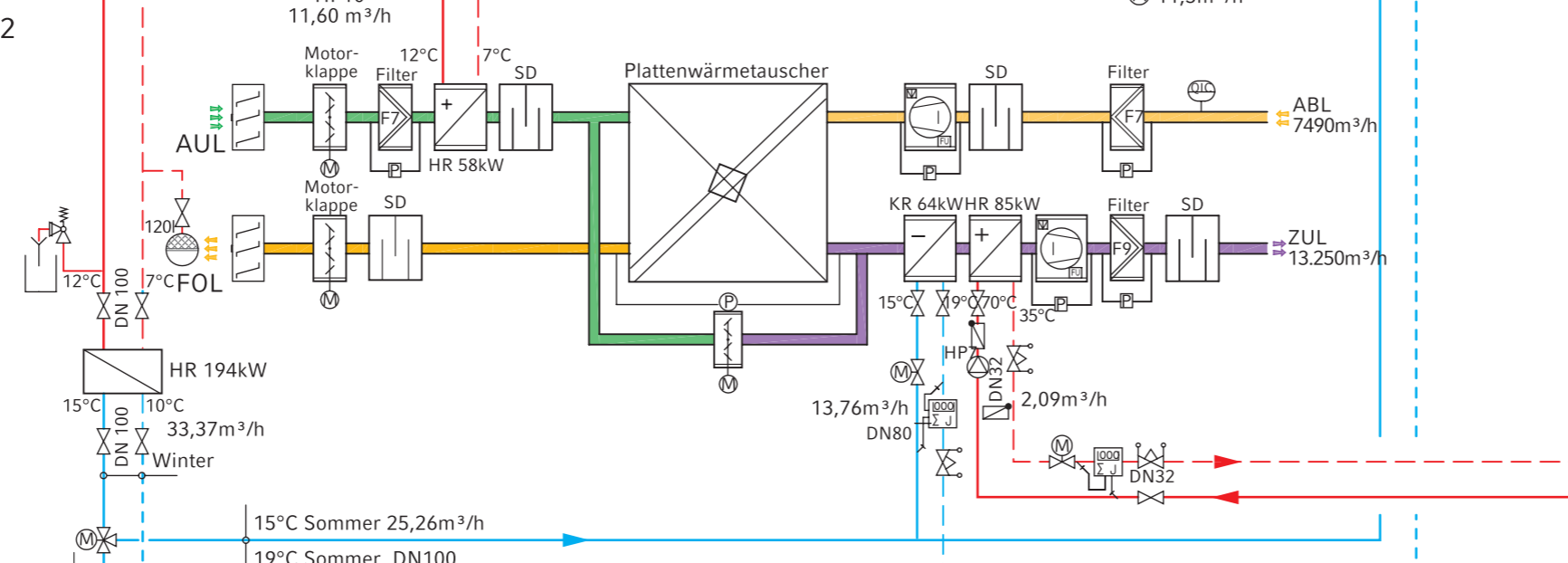

Verbraucher Kälte

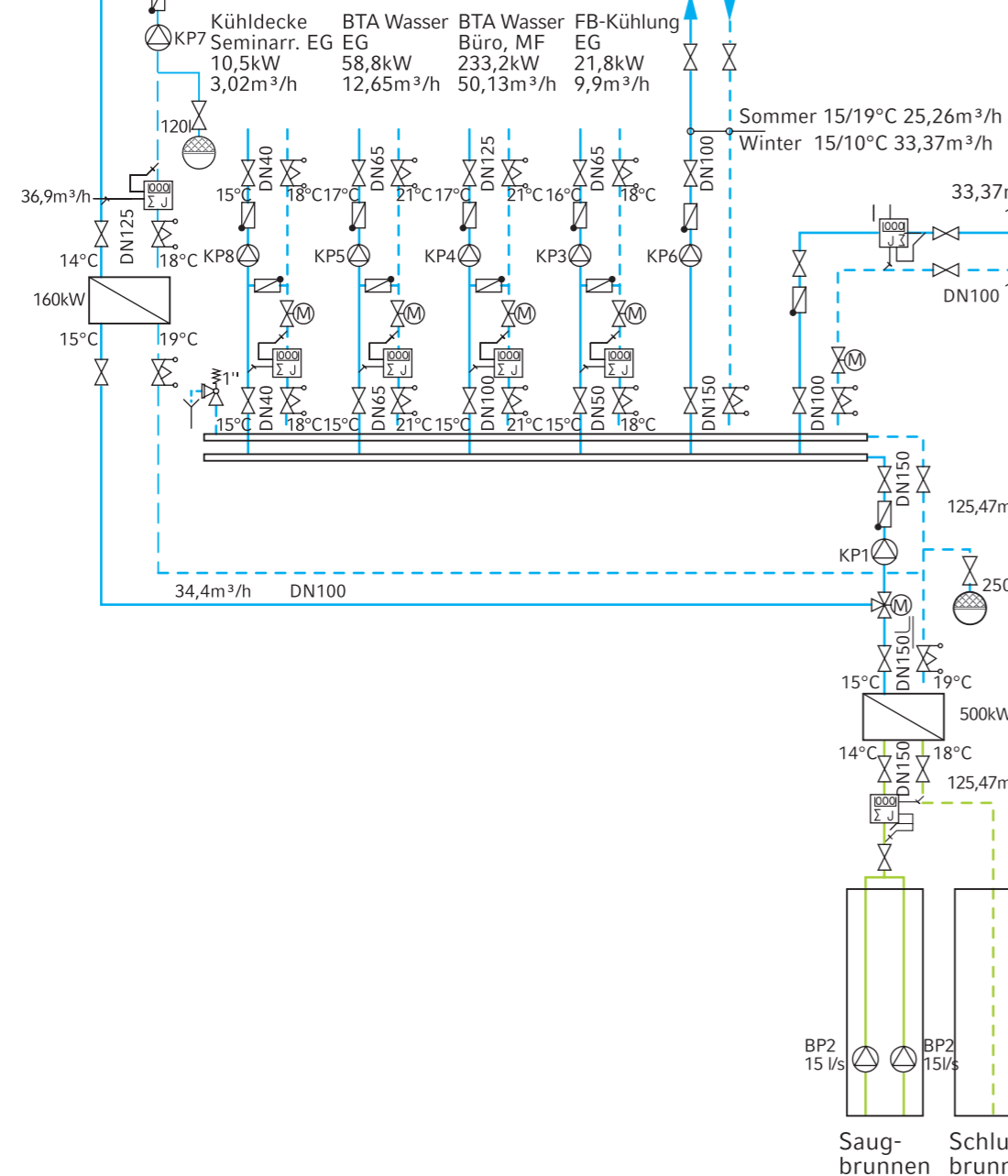

Kühldecke Seminar EG 10,5kW 3,02m³/h
 BTA Wasser Büro, MF EG 58,8kW 12,65m³/h
 BTA Wasser Büro, MF EG 233,2kW 50,13m³/h
 FB-Kühlung EG 21,8kW 9,9m³/h

Kleinwärmepumpen EDV-Räume Energieschiene

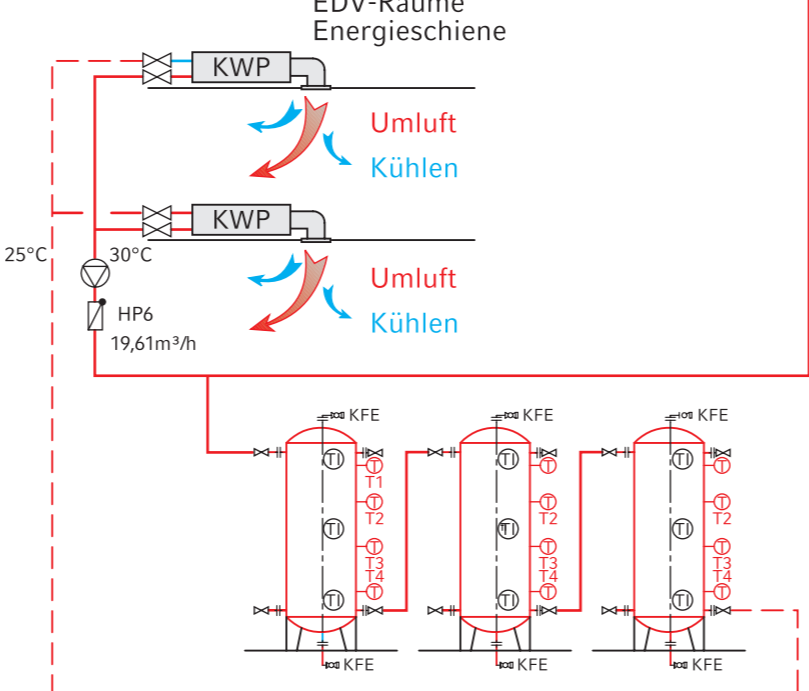

Pufferspeicher 3 x 2000 Liter

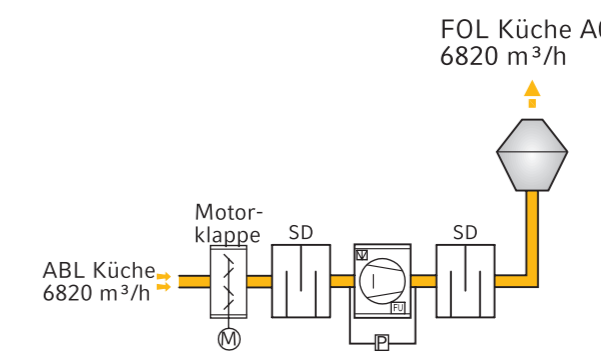

Verbraucher Heizung

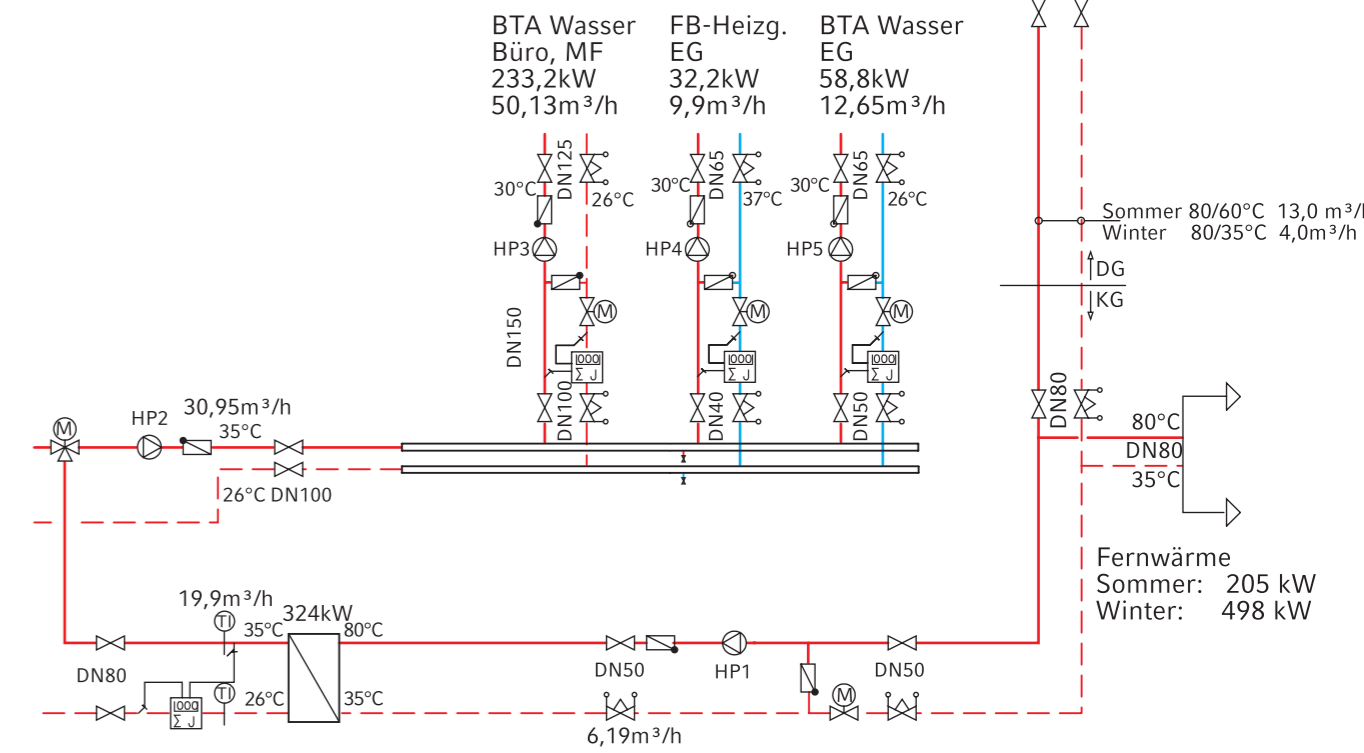

BTA Wasser Büro, MF 233,2kW 50,13m³/h
 FB-Heizung EG 32,2kW 9,9m³/h
 BTA Wasser EG 58,8kW 12,65m³/h

Fernwärme Sommer: 205 kW
 Winter: 498 kW

